

Installation Guide

Base Isolator

Step 1

Fix a 50mm x 50mm x 1.5mm galvanised steel angle into the masonry around the base plate using 40mm M6 masonry screws or anchors.

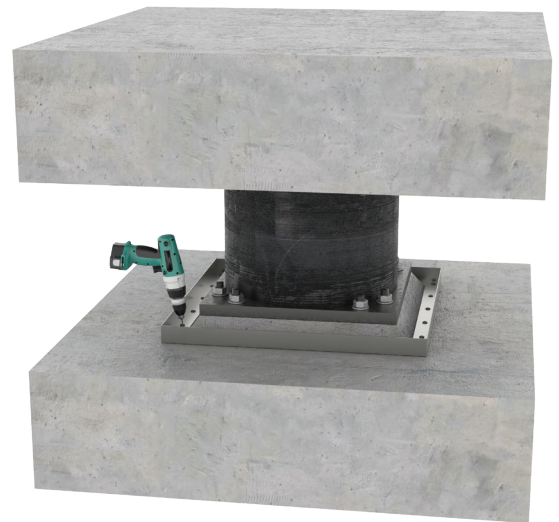

Step 2

Fix a 50mm x 50mm x 1.5mm galvanised steel angle into the masonry around the head plate using 40mm M6 masonry screws or anchors.

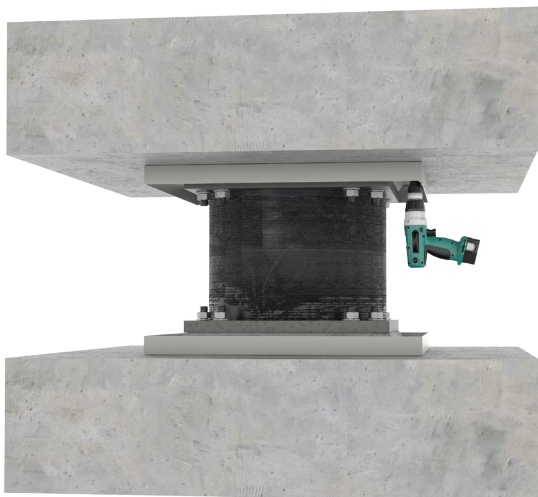

Step 3

Install the FIREFLY Titan fabric into position by temporarily pinning it back to the angles using tek screws. Ensure that it is belled out sufficiently to allow for the maximum required movement of the base isolator. Ensure that the FIREFLY Titan fabric is lapped by a minimum 100mm onto the masonry both top and bottom.

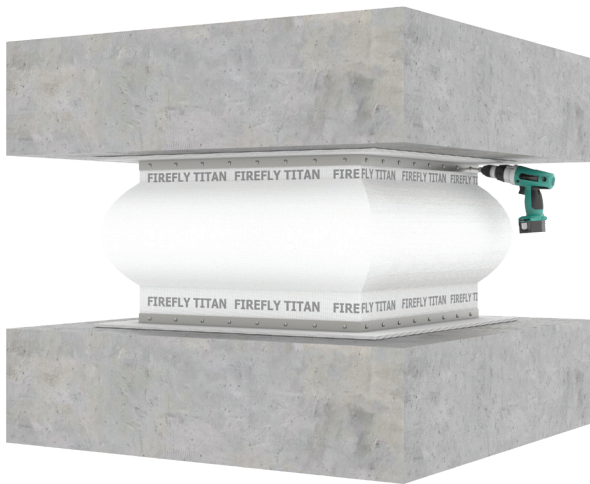
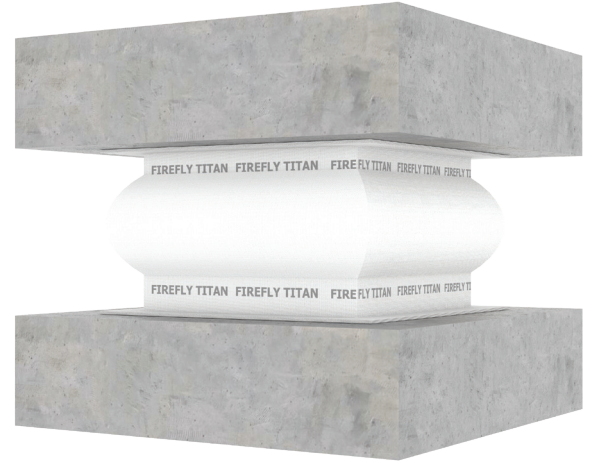

Step 4

Clamp the fabric back to the steel angles using 30mm x 0.6mm steel hoop irons fixed at 100mm centers using 32mm self-tapping screws.