

COMING SOON!

We are excited to share some of our new systems, making their way from the test lab to our reports and FIREFLY PFP, for desktop & App soon!

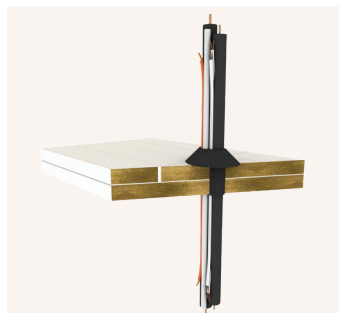

Up to 10 x DN32 copper pipes lagged with up to 32 mm Nitrile rubber insulation, plus up to 10 x 2.5 mm² 2C+E TPS electrical cables



3/8" + 5/8" FR copper pair coil with 19 mm Nitrile rubber foam insulation plus 6 mm² 3C+E cable, plus 20 mm condensate drain pipe, a CAT6 cable and 2.5 mm² TPS 2C+E TPS electrical cable

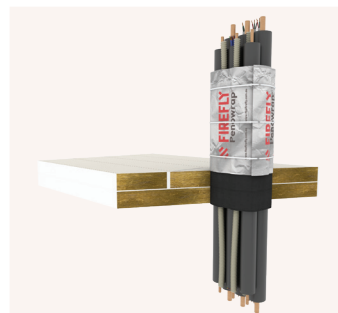

Up to 3 x 3/8" FR copper pair coil with 19 mm Nitrile rubber foam insulation plus 6 mm² 3C+E cable, plus 18 mm condensate drain pipe, a CAT6 cable and 2.5mm² TPS 2C+3 TPS electrical cable

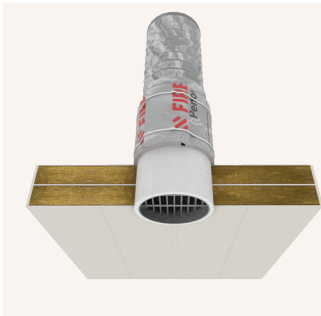

Lorient LVH44C intumescent fire damper with spigot and flexi duct

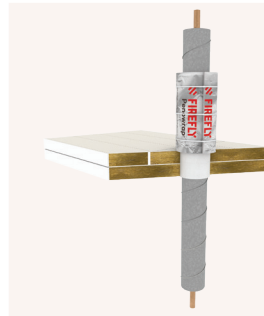

25.4 mm OD copper pipe with PUR insulation (WT 38 mm) clad in galvanised metal casing

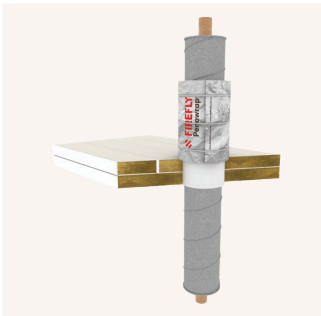

50.8 mm OD copper pipe with PUR insulation (WT 38 mm) clad in galvanised metal casing

Larger beer python tubes protected with FIREFLY FRF Collars:

In our recent testing, we evaluated a larger and more challenging beer python tube specimen. To ensure the safety of our customers, we have taken careful measures to protect the penetrations through which these tubes pass. Our solution involves utilising food-grade plastic, wrapped in a vapour barrier, and encased in nitrile rubber foam with a protective outer layer.

We tested a 130 mm overall OD beer python. The service penetration was sealed using a FIREFLY FRF 150 Fire Collar and FIREFLYMasticHP sealant. The remarkable result was an impressive 120-minute rating for both integrity and insulation. A smaller 40 mm overall OD beer python was tested with similar results.



Beer python, 130mm OD with FIREFLY FRF 150 Collar and FIREFLYMasticHP